



**IMPORTANT**

Carefully remove all the parts from the carton and place them individually on a soft cloth to prevent scratches or other damage.

Carefully and strictly follow these assembly instructions to ensure a completed product as designed.

Do not use power tools above 8 volts to assemble.

### Part List

- B. Side Panel** 1 pc.
- C. Middle Panel** 2 pcs.
- D. Side Panel** 1 pc.
- E. Back Panel** 2 pcs.
- F. Back Panel** 1 pc.
- G. Back Upright** 2 pcs.
- H. Back Rail** 1 pc.
- I. Front Rail** 1 pc.
- J. Base** 1 pc.
- K. Door** 2 pcs.
- L. Door** 2 pcs.
- M. Drawer Divider** 1 pc.
- N. Drawer** 2 pcs.  
Refer to later page(s) of these instructions for drawer assembly.
- O. Shelf** 2 pcs.
- P. Shelf** 1 pc.
- Q. Rack Side** 1 pc.
- R. Rack Side** 1 pc.
- S. Rack Base** 1 pc.

### Hardware List

- Caster** 2 Locking 4 pcs.
- Caster** 2 Non-Locking 4 pcs.
- Hex Wrench** 1 pc.
- Small Hex Wrench** 1 pc.
- M6x35 Head Cap Bolt** 11 pcs. (+1 extra)
- M3.5x25 Wood Screw (long)** 16 pcs. (+1 extra)
- M6x25 Head Cap Bolt for Towel Bar** 2 pcs. (+1 extra)
- M3.5x12 Wood Screw (short)** 12 pcs. (+1 extra)
- M6x20 Head Cap Bolt for Top** 4 pcs. (+1 extra)
- M4x25 Machine Screw** 12 pcs.
- M4x16 Wood Screw** 16 pcs. (+1 extra)
- Wood Plug** 9 pcs. (+1 extra)
- Spring Washer** 4 pcs. (+1 extra)
- Bracket** 4 pcs.
- Flat Washer** 4 pcs. (+1 extra)
- Handle** 6 pcs.
- Towel Bar** 1 pc.
- Pipe** 3 pcs.

20 09100 Top carton is also needed for assembly.

Tool(s) required for assembly: Phillips screwdriver

# Assembly Instructions 2/7

## IMPORTANT

- Use a soft cloth between these parts and the floor.
- Do not use power tools above 8 volts to assemble.
- Do not tighten all the screws until each part is properly assembled.
- Keep Hex Wrench as the bolts may need to be tightened in the future.

## STEP 1

Attach Side Panel (B) to Base (J) with Head Cap Bolts. (See Figure 1)

Attach Back Uprights (G) to Middle Panels (C), then attach to unit.

Note: Assemble so Arrow labels on Back Uprights (G) point to each other.

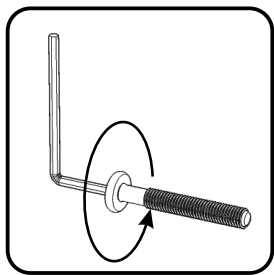
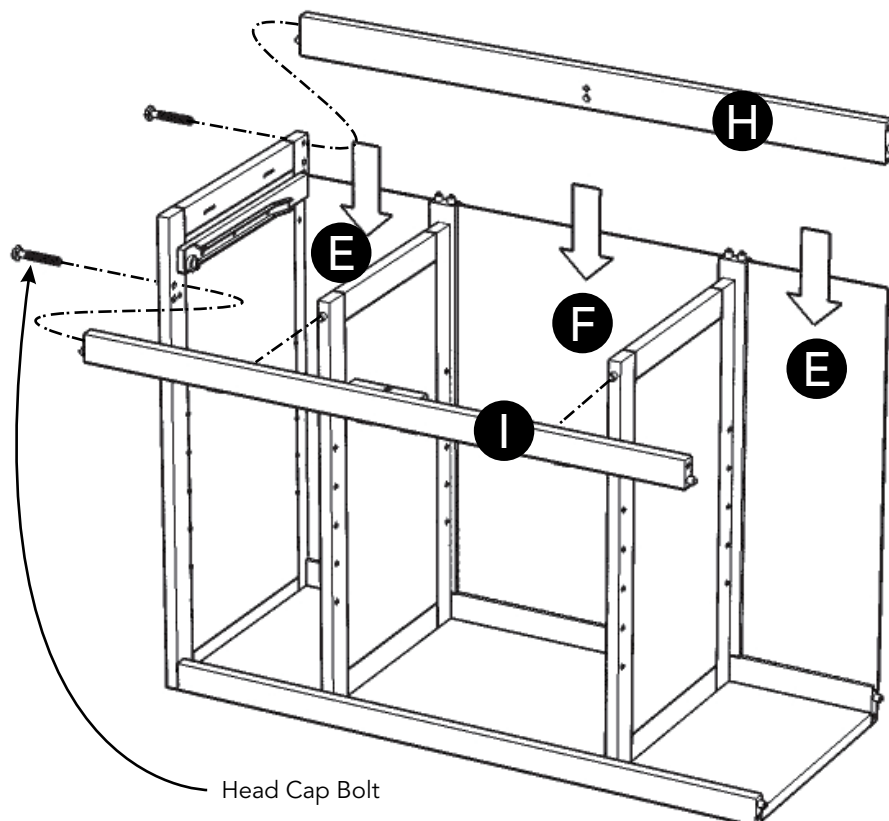
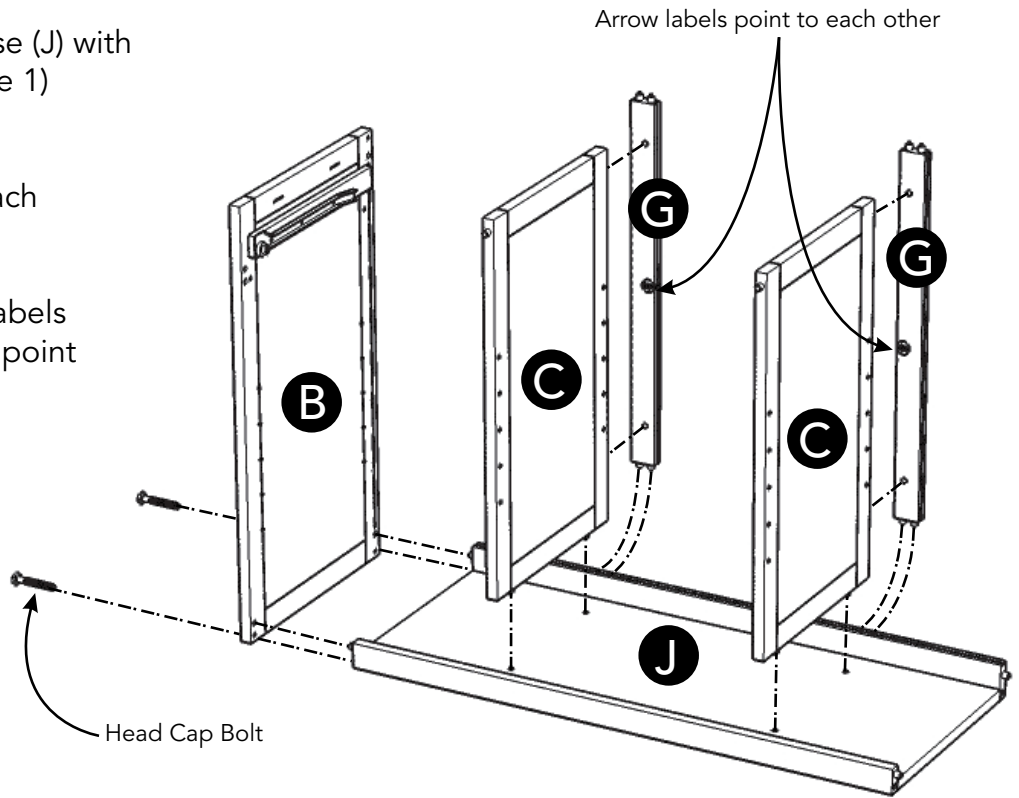

Figure 1



## STEP 2

Slide Back Panels (E) and (F) into position.

Attach Back Rail (H) to unit with Head Cap Bolt.

Attach Front Rail (I) to unit with Head Cap Bolt.

## Assembly Instructions 3/7

### STEP 3

Attach Drawer Divider (M) to unit with Head Cap Bolt.

Attach Side Panel (D) to unit with Head Cap Bolts.

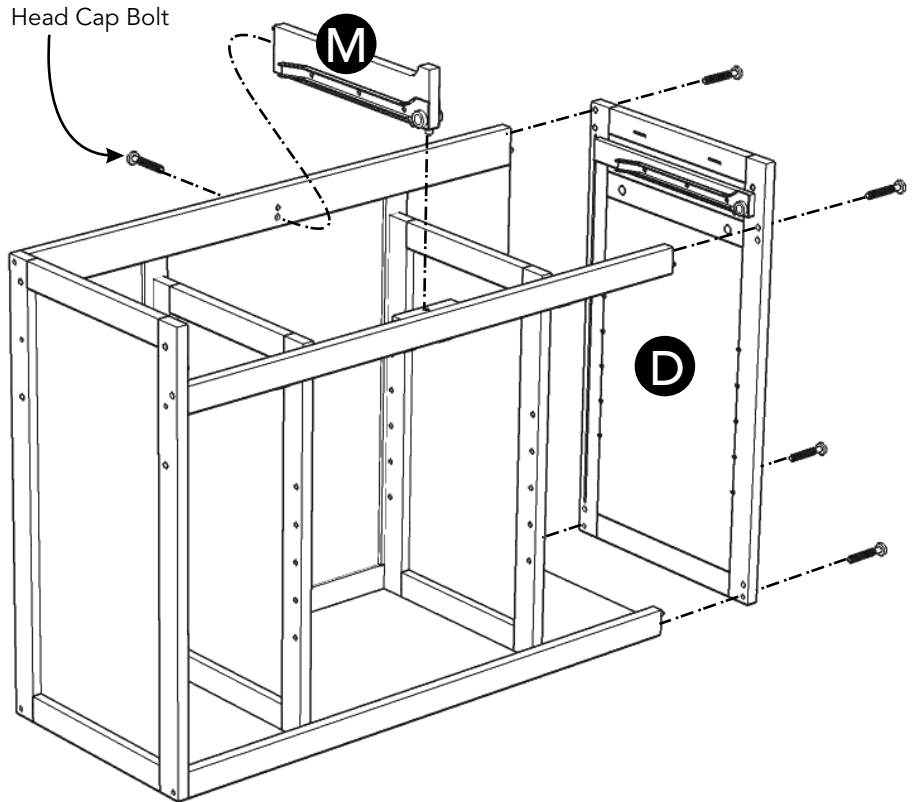

### STEP 4

Turn unit upside down.

Attach Casters to unit with Wood Screws into pre-drilled holes, with Locking Casters at front. (See Figure 2)

Note: Arrow label indicates front of unit.

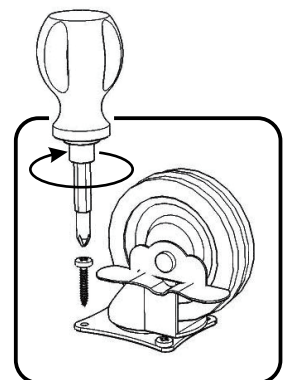
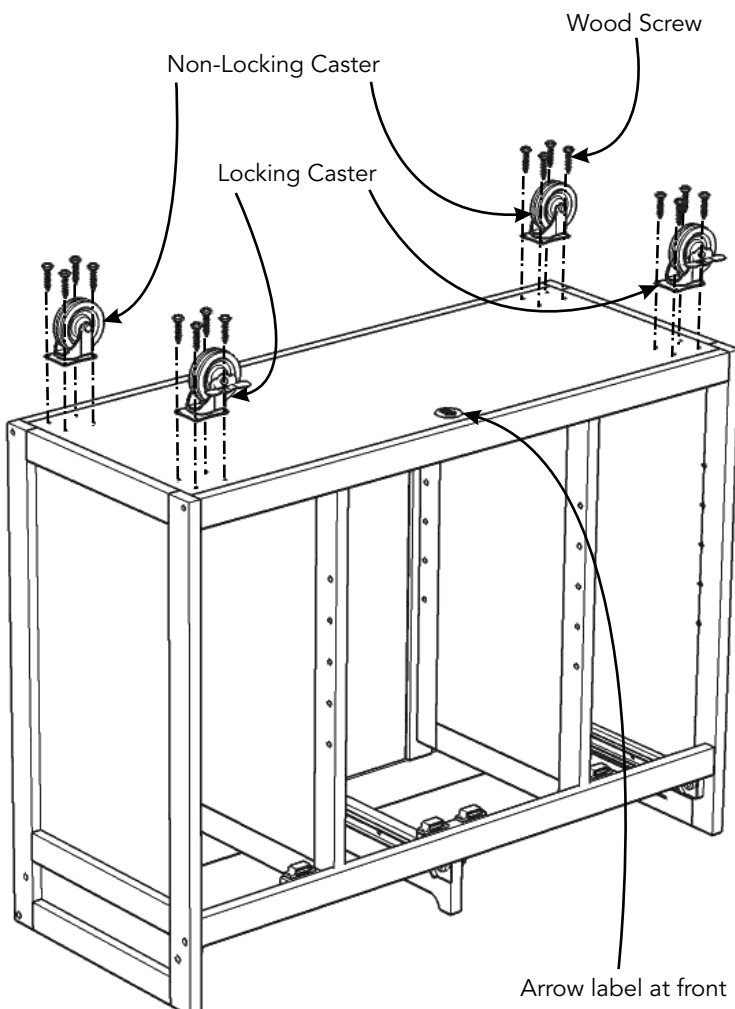

Figure 2

## Assembly Instructions 4/7

### STEP 5

Turn unit over to its upright position.

Attach Rack Side (R) to unit with Head Cap Bolt. (See Figure 3)

Slide Rack Base (S) and Pipes into Rack Side (R).

Attach Rack Side (Q) to unit with Head Cap Bolt.

Attach Towel Bar to unit with Head Cap Bolts for Towel Bar. (See Figure 4)

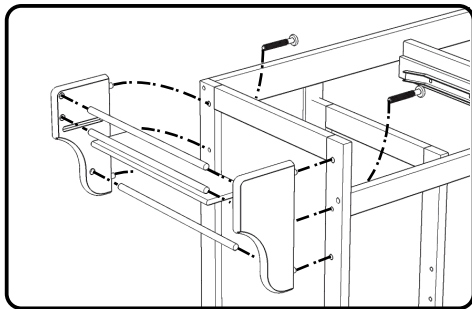
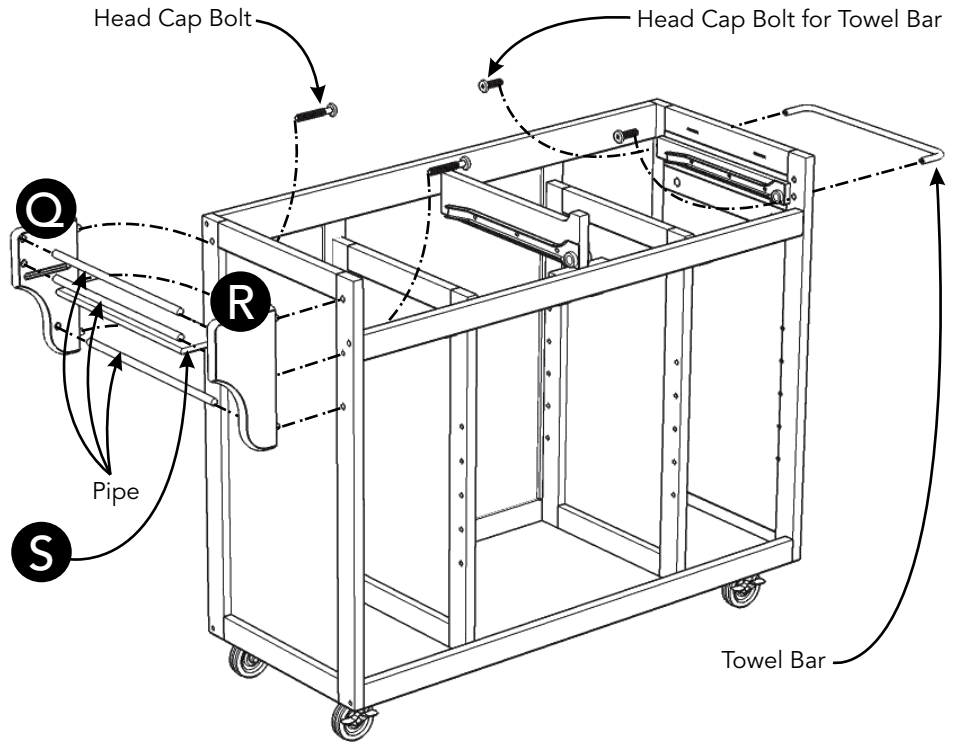

Figure 3

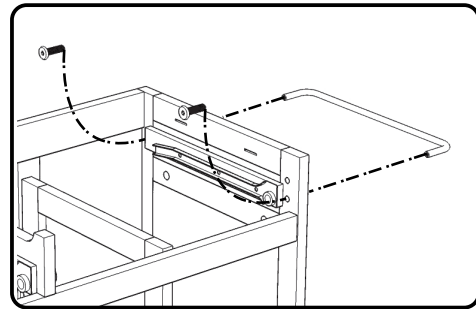
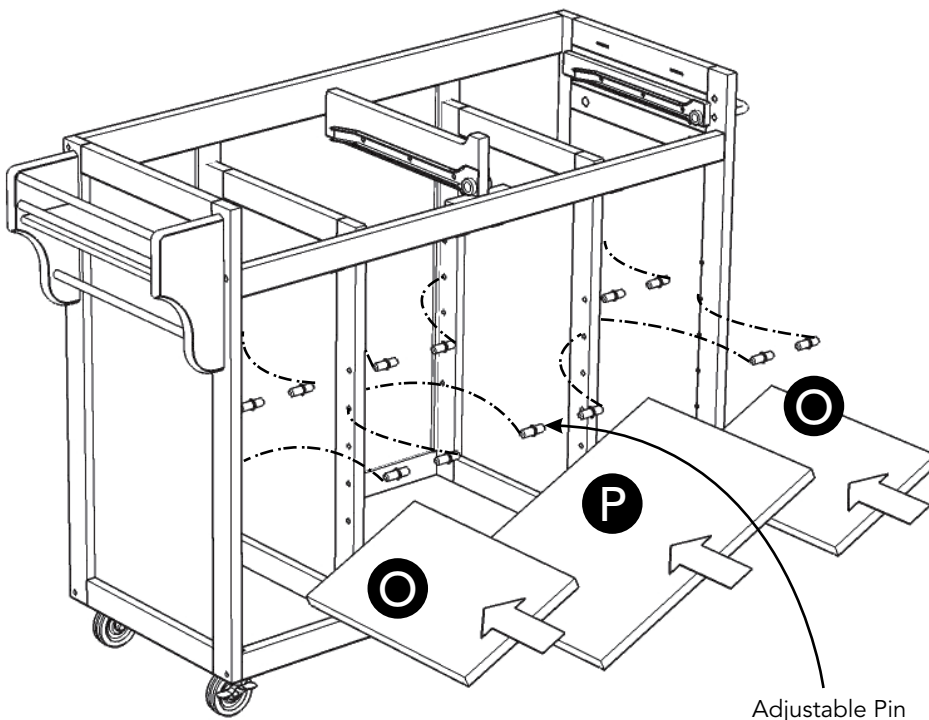

Figure 4



### STEP 6

Insert Adjustable Pins into side panels and middle panels at desired level.

Place Shelves (O) and (P) into position.

Adjustable Pin

## Assembly Instructions 5/7

### STEP 7

Attach Doors (K) and (L) by inserting lower spring pins into holes in unit, then inserting upper spring pins into holes in unit. (See Figure 5)

Attach Handles to Doors (K) and (L) with Machine Screws. (See Figure 6)

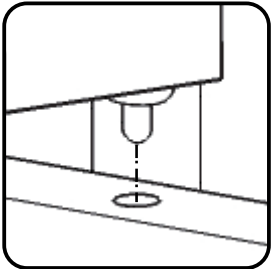
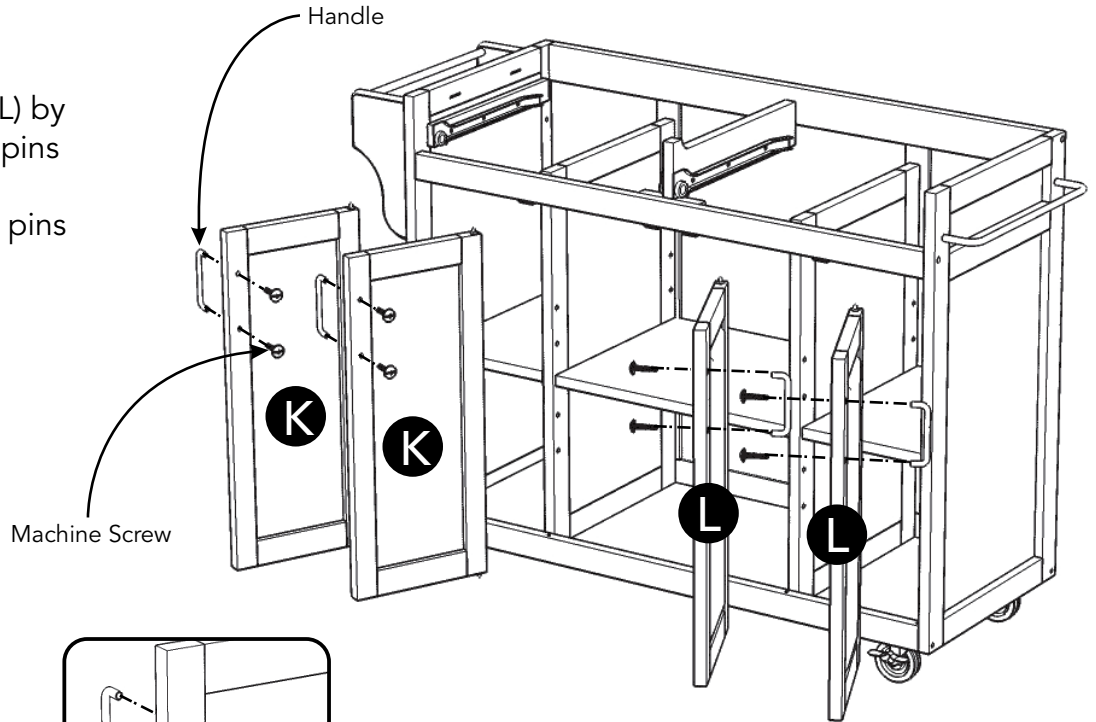

Figure 5

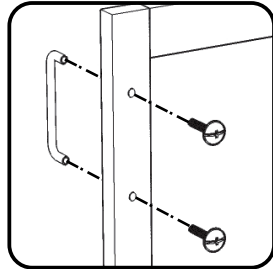
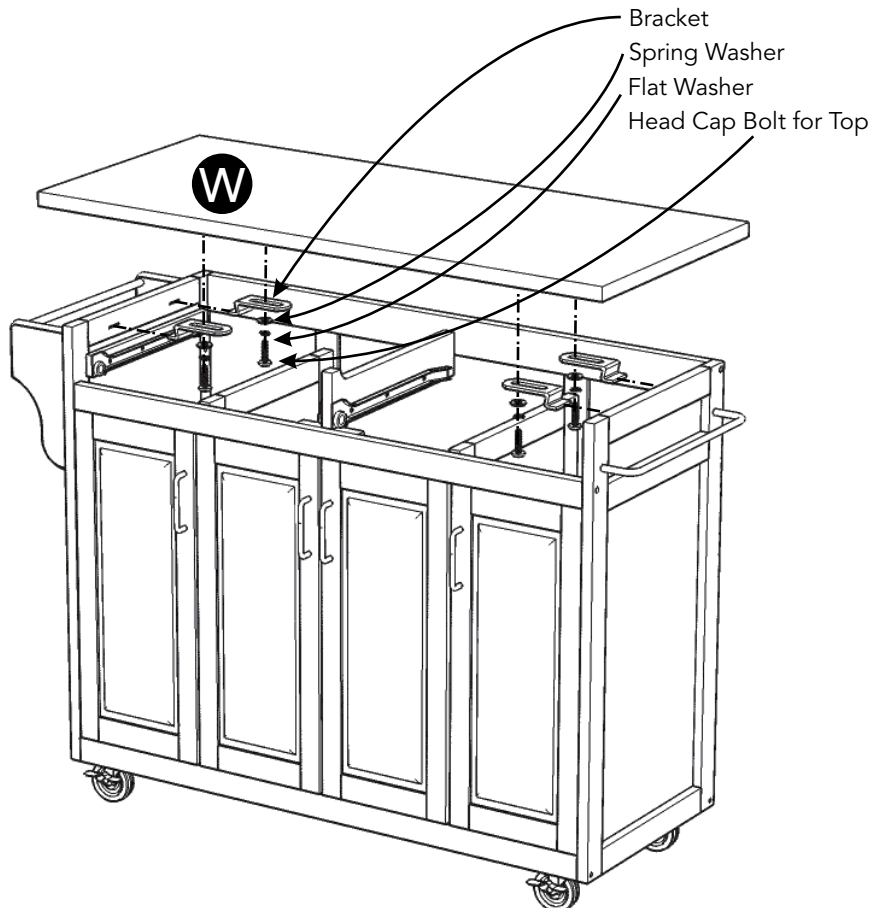

Figure 6



### STEP 8

Attach Top (W) to unit with Brackets, Flat Washers, Spring Washers and Head Cap Bolts for Top. (See Figure 7)

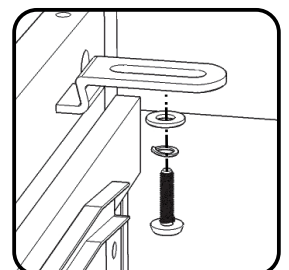
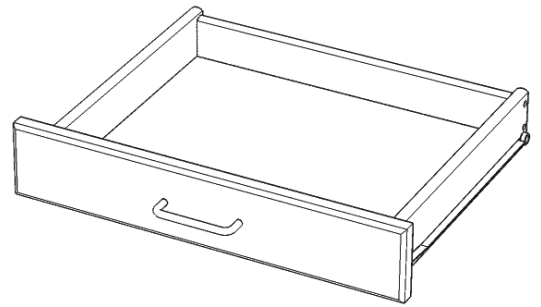

Figure 7

# Assembly Instructions 6/7

## Drawer (N)



### STEP 9

Attach Drawer Front (N1) and Drawer Back (N2) to Drawer Side (N3) with Wood Screws (long).

Attach Drawer Side (N4) to unit with Wood Screws (long).

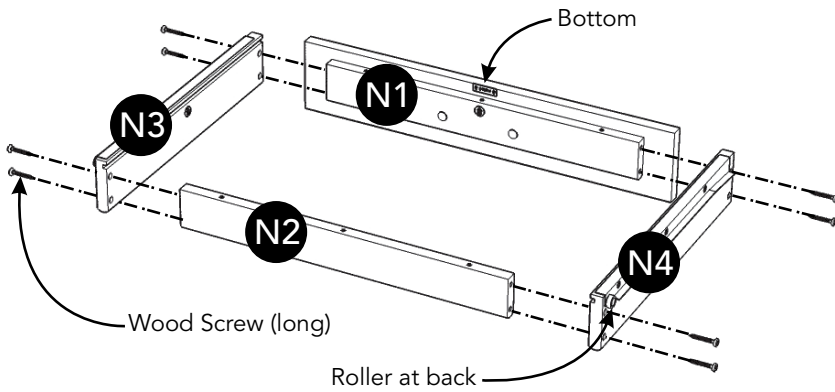

### STEP 10

Slide Drawer Bottom (N5) into groove.

Attach Drawer Bottom (N5) to unit with Wood Screws (short).

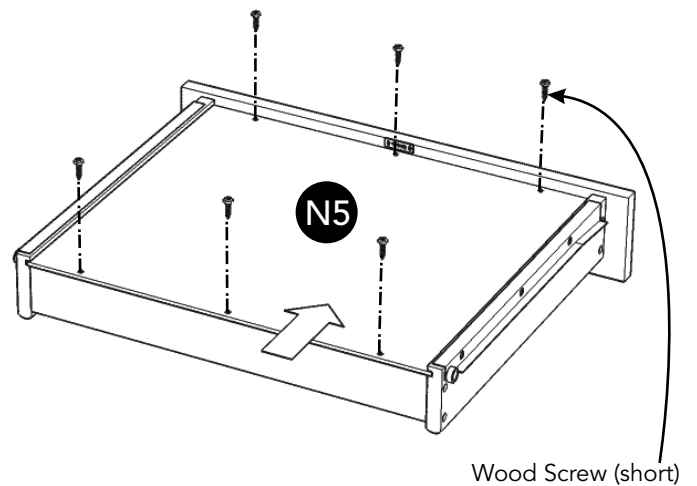

### STEP 11

Attach Handle with Machine Screws.

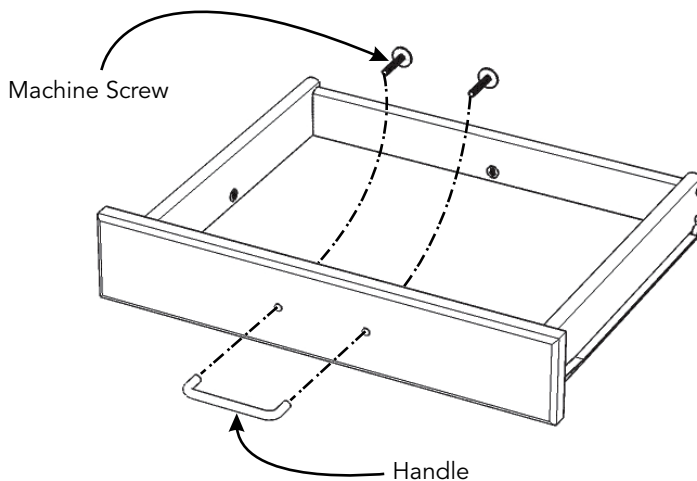

## Part List

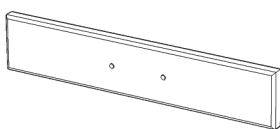

N1.  
Drawer Front  
2 pcs.

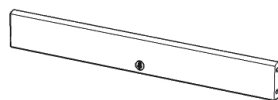

N2.  
Drawer Back  
2 pcs.

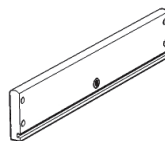

N3.  
Drawer Side  
2 pcs.

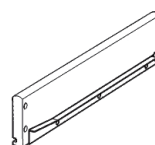

N4.  
Drawer Side  
2 pcs.

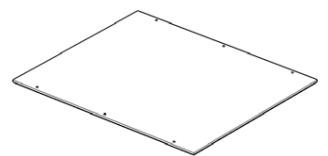

N5.  
Drawer Bottom  
2 pcs.

## STEP 12

Slide Drawers (N) into position.

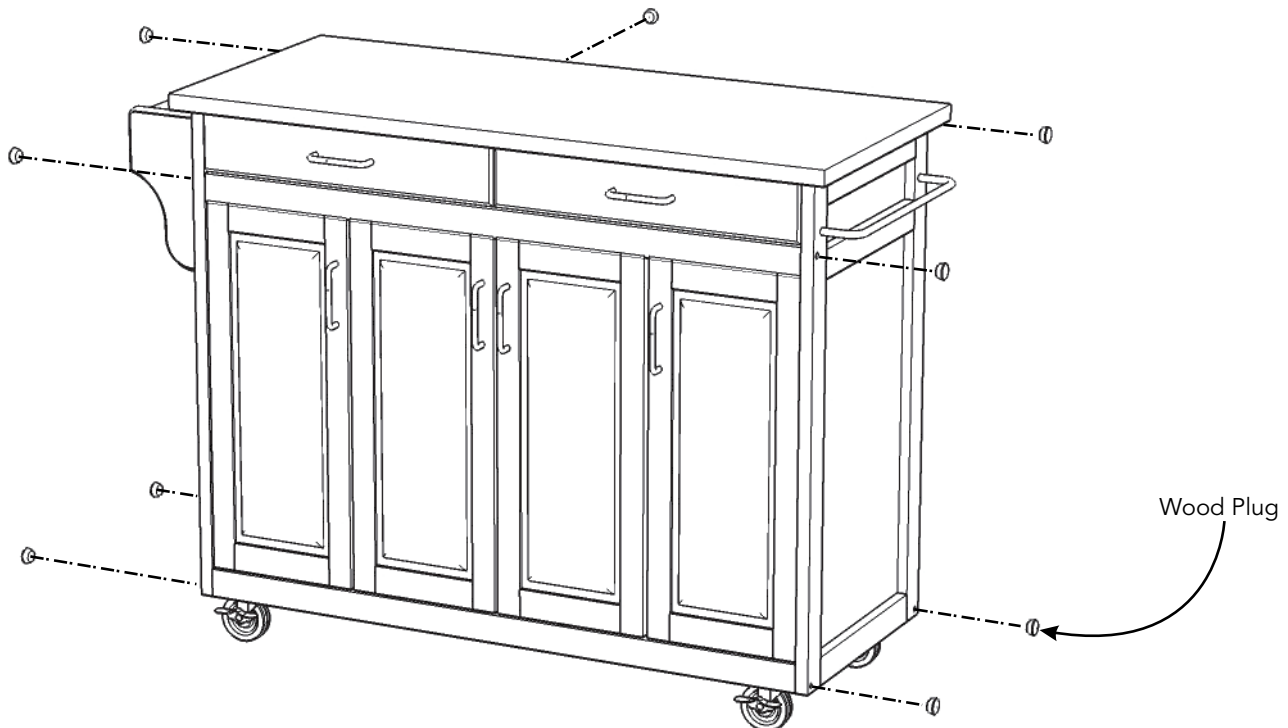
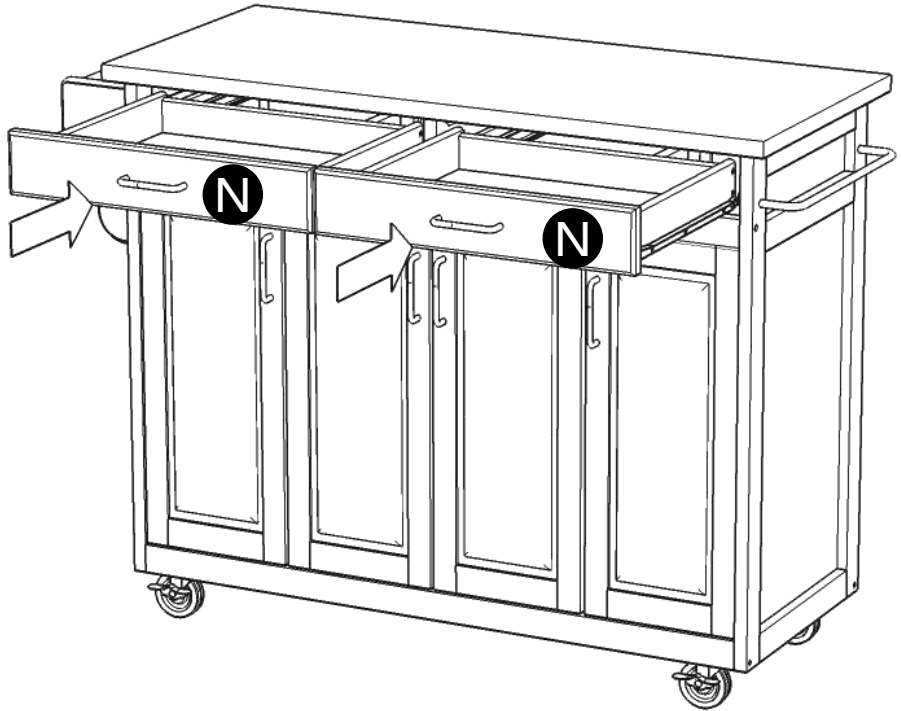

## STEP 13

Cover all holes with Wood Plugs.  
(See Figure 8)

Note: Supports (V) and Head Cap Bolts (middle) from  
20 09100 Top carton are not used in this assembly.

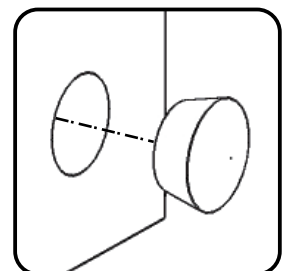

Figure 8

# CARE INSTRUCTIONS

## NEVER

allow liquids to remain on furniture.  
Absorption causes parts to warp  
and split and finishes to delaminate.

## NEVER

use glass cleaners on  
finished furniture. Ammonia  
chemically attacks the finish.



Do not use power tools  
above 8 volts to assemble.

**PREVENT  
CRACKING**



Do not place  
in direct sunlight.

**PREVENT  
FADING**



Do not write  
directly on surface.

**PREVENT  
MARKING**



Do not place hot  
objects on surface.

**PREVENT  
FINISH DAMAGE**

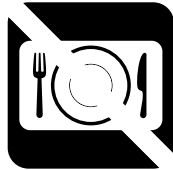

Do not use rubber  
based placemats.

**PREVENT  
DISCOLORING**



Do not use commercial  
waxes and polishes.

**PREVENT  
YELLOWING**

## CLEAN

with a soft cloth moistened  
in lukewarm soap and water.  
Buff with a dry clean cloth.



Home Styles will provide replacements free of charge for missing or damaged hardware or parts within 30 days of purchase. Digital images of the defective parts may be required. If the product was not purchased from an authorized retail affiliate, Home Styles is under no obligation to provide replacement parts. Parts are not available for fully assembled items nor are parts available for sale. Replacements for missing or damaged hardware or parts may be requested at:

[www.homestyles-furniture.com/customer-service/replacement-parts](http://www.homestyles-furniture.com/customer-service/replacement-parts)

Home Styles Customer Service: [www.homestyles-furniture.com](http://www.homestyles-furniture.com),  
[servicedesk@homestyles-furniture.com](mailto:servicedesk@homestyles-furniture.com), 888-680-7460, 877-831-0319